

# FM025 Centrifuge

## Technical Data



### BENEFITS

- Cleaner oil and extended oil life
- Lengthens service intervals
- Reduces engine wear
- Enhances long-term preventative maintenance
- Reduces maintenance costs
- Cuts waste disposal costs
- Reduces application down time
- Maximises in-service time for vehicle/engine/machine
- Reduces total cost of ownership
- Helps ensure clean combustion and fuel efficiency
- Supports engine technology for the reduction of exhaust emissions (e.g. exhaust gas recirculation)
- Fast return on investment

### DIMENSIONS (mm)

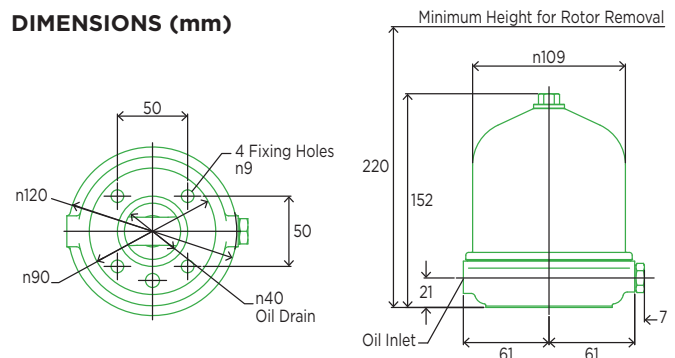

<b>Model</b>	<b>FM025-4</b>
<b>Part number</b>	6899111701
<b>Oil inlet thread</b>	Side 1/4" B.S.P.
<b>Cut Off Valve (C.O.V.) ratings</b>	1.3 bar
<b>Net weight</b>	1.4 kg
<b>System capacity</b>	5 - 15 litres for lubrication system
<b>Filter dirt capacity</b>	0.25 litres
<b>Filter oil capacity</b>	0.32 litres
<b>Minimum oil feed pipe size</b>	Ø 6 mm internal
<b>Minimum oil drain pipe size</b>	Ø 25 mm internal
<b>Rotor</b>	Cleanable

### PERFORMANCE CURVES

Typical Rotor Performance

