

FM400 Centrifuge

Technical Data



en 0817 © MANN+HUMMEL

BENEFITS

- Cleaner oil and extended oil life
- Lengthens service intervals
- Reduces engine wear
- Enhances long-term preventative maintenance
- Reduces maintenance costs
- Cuts waste disposal costs
- Reduces application down time
- Maximises in-service time for vehicle/engine/machine
- Reduces total cost of ownership
- Helps ensure clean combustion and fuel efficiency
- Supports engine technology for the reduction of exhaust emissions (e.g. exhaust gas recirculation)

DIMENSIONS (mm)

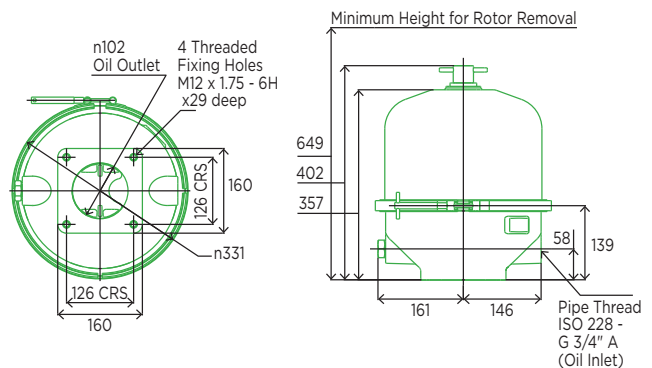

Model	FM400-23
Part number	68 991 38 801
Oil inlet thread	3/4" B.S.P.*
Cut Off Valve (C.O.V.) ratings	2.5 bar*
Threaded fixing holes	M12
Net weight	22 kg
System capacity	200 - 1,500 litres
Rotor dirt capacity	4 litres
Rotor oil capacity	4.5 litres
Minimum oil feed pipe size	Ø 19 mm internal
Minimum oil drain pipe size	Ø 76 mm internal

*Can be tailored to suit customer requirements

PERFORMANCE CURVES

Typical Rotor Performance for SAE 30 Oil @ 100°C

